

LLEPRECON 13

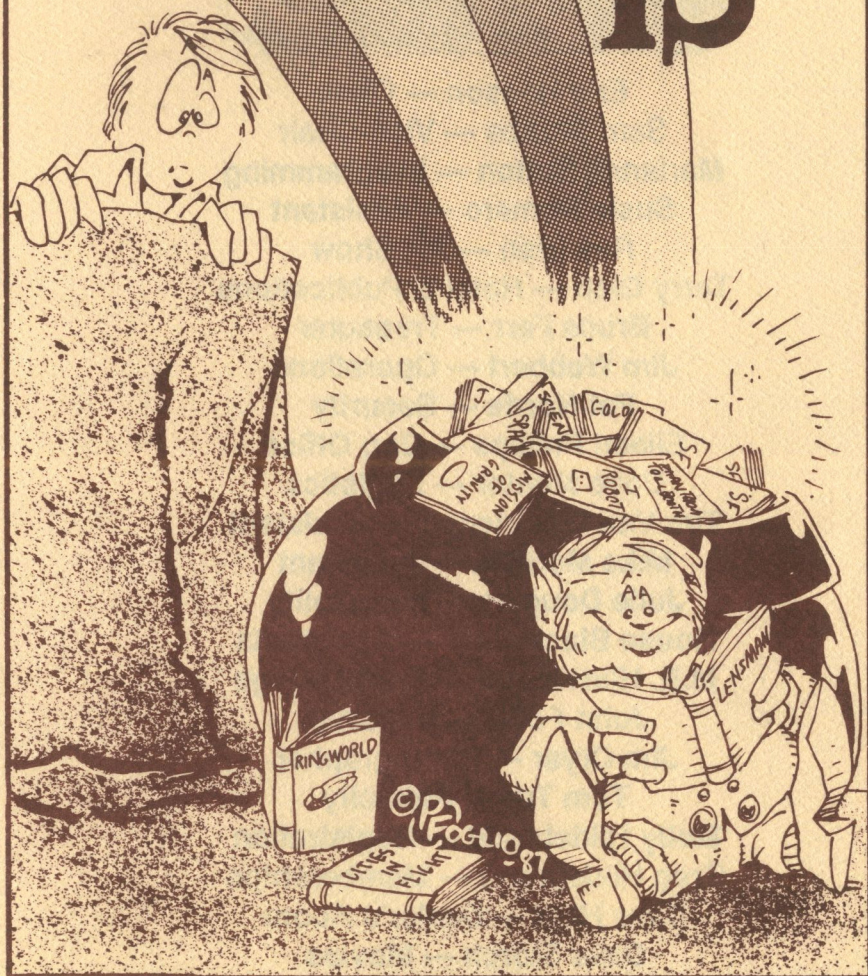

Phoenix, Arizona
June 5 - 7, 1987

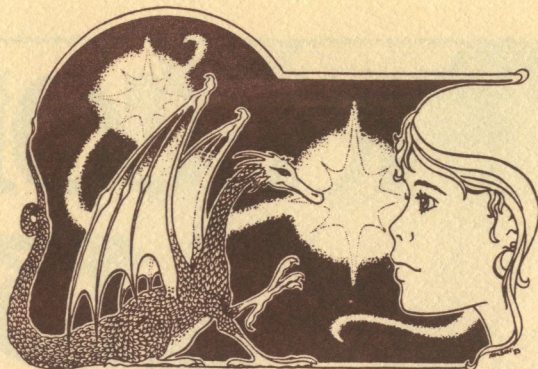

Eric Hanson --- Chair
Sam Stubbs --- Vice-Chair
Marianne Sutton --- Programming
Susie Romero --- Assistant
Ray Gish --- Art Show
Terry Gish --- Hotel & Publications
Bruce Farr --- Treasurer
Jim Webbert --- Operations
Pat Norris --- Security
Eileen Phillips --- Con Office
Dave Munter --- Logistics
Tim Van Westrienen --- Assistant
Mike Morison --- Assistant
Julie Douglas --- Hospitality
House Blackwater --- Assistants
M.R. Hildebrand --- Staff Lounge
John Fong --- Historian
Jim Cryer --- Photographer
Tom Tuerff-Publicity
Molly Hildebrand --- Registration
Greg Hildebrand --- Memberships
Dave Hiatt --- Dealer's Room
Dave Storch --- Movies
Tom Perry --- Japanimation
Ken Lemons --- Volunteers
Chip Pitcher --- Gaming
Bill Kendall ---Computers
Plus a Cast of Hundreds

LepreCon 73

June 5-7, 1987

Phoenix Hyatt Regency

Guests of Honor

Artist: Phil Foglio

Pro: Raymond Feist

Fan: Susan Potter



Thanks to the following artists: Phil Foglio, Real Musgrave, Ingrid Neilson, Bill Rotsler, Armand Cabrera, S. S. Crompton, Joshua Quarmire, Karen Kuykendall, Mary Hanson-Roberts, Alison Fiona Hershey, D. C. Dedon, Brian McCrary, and Alan Gutierrez for the art that graces this program book.

FROM THE CHAIR

Eric Hanson

Welcome to this, the culmination of efforts, that we so fondly call LepreCon 13. Every year we say the same thing, but it is true. You are all more than welcome to LepreCon. After all, you are the reason that we do this.

Conventions are put on by many people for different reasons, some because they like the work and others because they like the people. I could say that I did it because I couldn't run fast enough but then that would hide the real reason that started it all. Conventions are put on year after year because people have fun in doing it. And that is the only reason that we come back year after year, because we do have fun with it. But in stating this I do have to say that I thank you for coming and joining us, for it wouldn't be as much fun without you.

The friendships that we make while we are working and attending conventions are all of the payment that we receive, but in that we are wealthy beyond our dreams. These friendships are sometimes brief, sometimes lasting a lifetime, but they all share a deep intensity because we all share the same love of life. I have learned more about myself and about the others that I have worked with and the feeling of satisfaction that we have gained will last a lifetime, long after the convention has passed on. It is this coin that I could never trade away, the coin of the convention. And for this I wish to thank all of you who are attending this convention, for without you I could not have done any of this.

I would also like thank this years committee for all of the hard work and support you have given, by your labors I can walk a little higher now. Mariann, you have created the Programming out of your head and made it look easy. Chip, you even have me interested in Gaming. Sam, you had the hardest job of all, but you kept me on track and I could always count on you. Dave, you have filled the Dealers Room every year and still find time to enjoy life. Ray, your Art Shows are the best that I have ever seen. Dave, you walked in and put together an outstanding Video program. Julie, who will care for all of us in her very hospitable Con Suite. Pati, your Masquerades are always very entertaining. Eileen, who keeps it all together and on track. Jim, we

may not see eye to eye all of the time, but I trust you like I trust myself. Pat, your idea of Security, but I never said you were too tall. Greg and Molly, you have kept track of all of us. Bruce, who keeps us fiscally responsible. And to all of you who are too numerous to mention and whose work for this convention has made all of us breath easier, **THANK YOU ALL VERY MUCH.** And lastly to you Terry, without your help I never would have made it this far. Congratulations with ConQuistador, you really deserve the honor.

All of us hope that you enjoy yourself at this year's convention. Remember that you will only get out of the convention what you put into it. If you have a good time while you are here, please mention it to one of the committee or staff, for they are the ones that have done all of the work so that we could enjoy ourselves this weekend. Thank you again for coming and I hope to see you for many years to come.

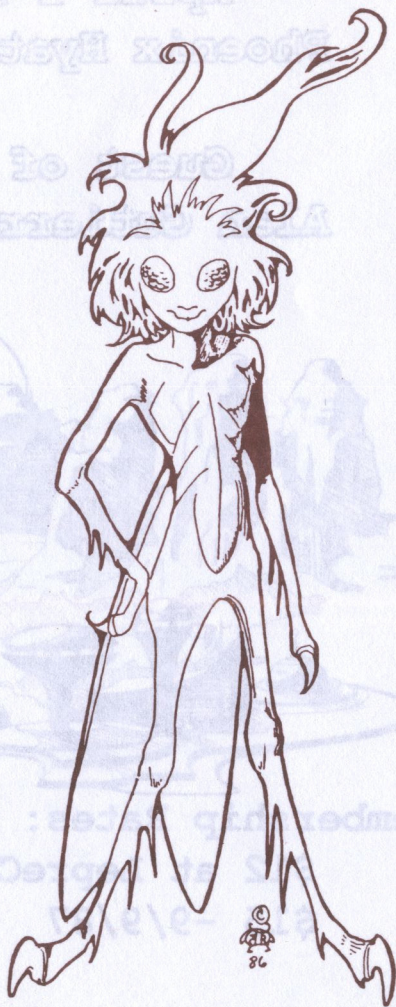

HELP WANTED

Jobs/Part time—Fans willing to work. Flexible hours. Possible membership reimbursement. Variety of jobs. No skills or experience needed. Must be willing to have fun on the job. For Further information — See Ken Lemons in Remington C.

Leprecon 14

April 1-3, 1988

Phoenix Hyatt Regency

Guest of Honor

Alan Gutierrez-Artist

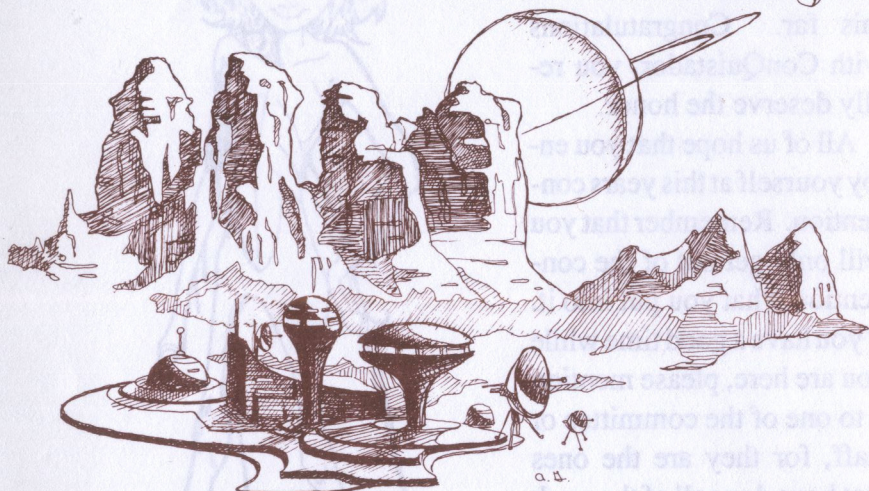

Membership Rates:

\$12 at LepreCon 13

\$15 -9/9/87

Room Rates:

\$55 Single/Double/Triple

Information and Memberships:

P.O.Box 26665

Tempe, AZ 85282

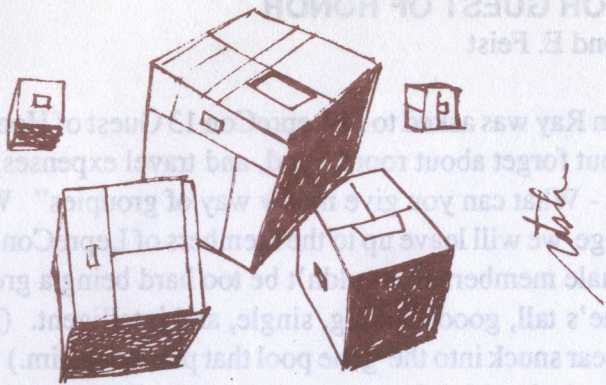

ARTIST GUEST OF HONOR

Phil Foglio

As you have probably notice from your badge and the program book cover, Phil Foglio is a talented cartoonist. He has a unique ability to see the same things everyone sees but with a quirky twist. The covers and interior illustrations of several of Robert Asprin's Myth series, where he illustrated the adventures of Skeve and his friends, are probably among his best known works but he has also contributed to several mainstream magazines, and several comic style books. Phil's work has shown up in fan publishing for years too, recently promoting the Bermuda Triangle in 88 WorldCon bid. At Denvention Gary Kurtz and the Insidious Heydt Combine got into a bidding war for one of Phil's pieces. As far as we know, that piece showed the greatest percentage price increase ever seen in an SF/F art auction. Its' price went from around \$35 to over \$500. That piece featured the final warehouse scene from "Raiders of the Lost Ark" where packing crates were conversing in the warehouse and introducing themselves as wonderful inventions, like an engine that runs on water and a perpetual motion machine. The last balloon said "I think I'm in the wrong place. I'm only an electric pencil sharpener."

Phil's not only talented with a pen, he is fun to be around. He's been known to show up at conventions in anything from a Hawaiian shirt to a white tux. He will be assisting with our art auction and that can be a real treat, as Phil sense of humor is not always limited to his drawing board.

AUTHOR GUEST OF HONOR

Raymond E. Feist

When Ray was asked to be LepreCon 13 Guest of Honor he replied "Yes, but forget about room, food, and travel expenses, lets get real serious - What can you give me by way of groupies" Well, this is a challenge we will leave up to the members of LepreCon to meet. For the female members it shouldn't be too hard being a groupie of Ray Feist, he's tall, good-looking, single, and intelligent. (I think some teddy bear snuck into the gene pool that produced him.) For the male members it shouldn't be too tough either, as Ray is very likeable and a pleasure to talk to.

When we asked him what he would like us to tell you about himself. He said "I was born, I live in California, and I write. The work should speak for itself" We agree and so does the rest of the world. Two of Ray's books have been on best seller lists. Darkness of Sethanon has been on the New York best seller list and Silverthorn was on the Australian list. These books are part of the Riftwar Saga and richly deserve the honor. We will be including an excerpt from Magician: Apprentice which should give those of you who haven't read any of Ray's work a chance to get hooked.



While the WorldCon is out of the country,
Phoenix is celebrating with an
OUT*OF*THIS*WORLD*CON

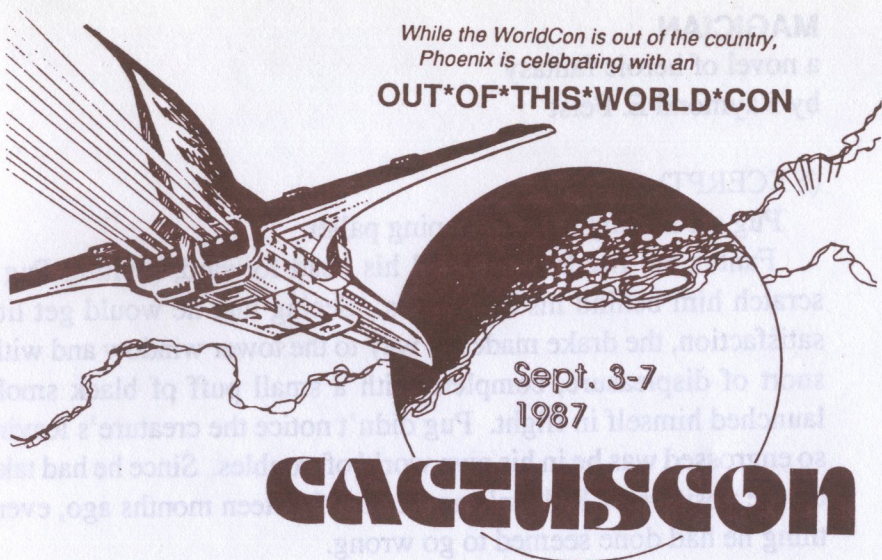

Sept. 3-7
1987

CACULUSCON

PHOENIX, ARIZONA

at the Hyatt Regency &
Phoenix Civic Plaza

also: the Phoenix Hilton (formerly the Adams Hotel); the
Heritage Hotel; the San Carlos Hotel.

RATES: \$40 thru 5/31/87 \$50 thru 8/15/87
\$60 at the door
Children under 13, 1/2 Price

HOTEL ROOMS: Write for our Special Reservation
forms. (Sent automatically to new members)

NASFIC**

(North American Science Fiction Convention)

**3000-5000
Attendance Expected**

PROG OH: HAL CLEMENT

FAN GOH: MARJII ELLERS

TOASTMASTER: JULIUS SCHWARTZ

and Robert Adams * David Lee Anderson * Ed Bryant
Sprague De Camp * Stephen R. Donaldson * George
Alec Effinger * David Gerrold * Alan Gutierrez * Jullian
May * Larry Niven * James Odbert * Richard Pini
Jennifer Roberson * G. Harry Stine * Jack Williamson

... and hundreds more!

FEATURING: Spectacular Art Show * Huge Dealers'
Room (sold out) * LUCAS FILMS 10 Year Anniversary
Celebration * Expanded Gaming Program * Original
Film & Video Competition * Two Costume Events
Dance Programs * Exhibit Hall * Special Children's
Programming * PHOTON Tournament * Workshops
Panels * Readings * Parties * and Lots More!!!!!!

MEMBERSHIP APPLICATION

Name(s) _____

Address _____

City _____ State _____ Zip _____

Phone _____ I am Interested in volunteering

Experience and/or preference _____

Amount enclosed for membership(s) \$ _____

(also see reverse side)

Information requested about _____
(please enclose SASE)

P. O. Box 27201 * Tempe, Arizona 85282 USA

Phone (602) 968-5673

MAGICIAN

a novel of heroic fantasy

by Raymond E. Feist

(EXCERPT)

Pug sat sulking on his sleeping pallet.

Fantus the fire Drake pushed his head forward, inviting Pug to scratch him behind his eye ridges. Seeing that he would get little satisfaction, the Drake made his way to the tower window and with a snort of displeasure, complete with a small puff of black smoke, launched himself in flight. Pug didn't notice the creature's leaving, so engrossed was he in his own world of troubles. Since he had taken on the position of Kulgan's apprentice fourteen months ago, everything he had done seemed to go wrong.

He lay back on the pallet, covering his eyes with a forearm. Everything in his life had taken a turn for the better since his apprenticeship, except the single most important thing, his studies.

For months Kulgan had been laboring to teach him the fundamentals of the magician's arts, but there was always something that caused his efforts to go awry. In the theories of spell casting, Pug was a quick study, grasping the basic concepts well. But each time he attempted to use his knowledge something seemed to hold him back. It was as if a part of his mind refused to follow through with the magic, as if a block existed that prevented him from passing a certain point in the spell. Each time he tried he could feel himself approach that point, and like a rider of a balky horse, he couldn't seem to force himself over the hurdle.

Kulgan dismissed his worries, saying that it would all sort itself out in time. The stout magician was always sympathetic with the boy, never reprimanding him for not doing better, for he knew the boy was trying.

Pug was brought out of his reverie by someone's opening the door. Look-



ing up, he saw Father Tully entering, a large book under his arm. The cleric's white robes rustled as he closed the door. Pug sat up.

"Pug, it's time for your writing lesson—" He stopped himself when he saw the downcast expression of the boy. "What's the matter, lad?"

Pug had come to like the old priest of Astalon. He was a strict master, but a fair one. He would praise the boy for his successes as often as scold him for his failures. He had a quick mind and a sense of humor and was open to questions, no matter how stupid Pug thought they might sound.

Coming to his feet, Pug sighed. "I don't know, Father. It's just that things don't seem to be going right. Everything I try, I manage to make a mess of."

"Pug, it can't be all black," the priest said, placing a hand on Pug's shoulder. "Why don't you tell me what is troubling you, and we can practice writing some other time." He moved to a stool by the window and adjusted his robes around him as he sat. As he placed the large book at his feet he studied the boy.

Pug had grown over the last year, but was still small. His shoulders were beginning to broaden a bit and his face was showing signs of the man he would someday be. He was a dejected figure in his homespun tunic and trousers, his mood as grey as the material he wore. His room, which was usually neat and orderly, was a mess of scrolls and books, reflecting the disorder in his mind.

Pug sat quietly for a moment, but when the priest said nothing, started to speak. "Do you remember my telling you that Kulgan was trying to teach me the three basic cantrips to calm the mind, so that the working of spells could be practiced without stress? Well, the truth is that I mastered those exercises months ago. I can bring my mind to a state of calm in moments now, with little effort. But that is as far as it goes. After that, everything seems to fall apart."

"What do you mean?"

"The next thing to learn is to discipline the mind to do things that are not natural for it, such as think on one thing to the exclusion of everything else, or not to think of something, which is quite hard once you've been told what it is. I can do those things most of the time, but

Ingrid Neilson





Southern California Institute For Fan Interests, Inc.

P.O. Box 8442 • Van Nuys, CA 91409

now and again I feel there are some forces inside my head, crashing about, demanding that I do things in a different way. It's like there was something else happening in my head the what Kulgan told me to expect."

"Each time I try one of the simple spells Kulgan taught me, like making an object move, or lifting myself off the ground, these things in my head come flooding in on my concentration and I lose my control. I can't even master the simplest spell." Pug felt himself tremble, for this was the first chance to speak about this to anyone beside Kulgan. "Kulgan simply says to keep at it and not worry." Nearing tears, he continued, "I have talent. Kulgan said he knew it from the first time we met, when I used the crystal. You've told me that I have talent. But I just can't make the spells work the way they're supposed to. I get so confused by it all."

"Pug," said the priest, "magic has many properties, and we understand little of how it works, even those of us who practice it. In the temples we are taught that magic is a gift from the Gods, and we accept that on faith. We do not understand how this can be so, but we do not question. Each order has it's own province of magic, with no two quite alike. I am capable of magic that those who follow other orders are not. But none can say why."

"Magicians deal in a different sort of magic, and their practices are very different from our practices in the temples. Much of what they do, we cannot. It is they who study the art of magic, seeking it's nature and workings, but even they cannot explain how magic works. They only know how to work it, and pass that knowledge along to their students, as Kulgan is doing with you."

"Trying to do with me, Father. I think he may have misjudged me."

"I think not, Pug. I have some knowledge of these things, and since you have become Kulgan's pupil I have felt the power growing in you. Perhaps you will come to it late, as others have, but I'm sure you will find the proper path."

Pug was not comforted. He didn't question the priests wisdom or his opinion, but he did feel he could be mistaken. "I hope your right, Father. I just don't understand what's wrong with me."

"I think I know what's wrong," came a voice from the door. Startled, Pug and Father Tully turned to see Kulgan standing in the

doorway. His blue eyes were set in lines of concern, and his thick grey brows formed a V over the bridge of his nose. Neither Pug or Tully had heard the door open. Kulgan hiked his long green robe and stepped into the room, leaving the door open.



“Come here, Pug,” said the magician with a small wave of his hand. Pug went over to the magician, who placed both hands on his shoulders. “Boys who sit in their rooms day after day worrying about why things don’t work make things not work. I’m giving you the day for yourself. As it is Sixthday, there should be plenty of other boys to help you in whatever sort of trouble boys can find.” He smiled, and his pupil was filled with relief. “You need a rest from study. Now go.” So saying, he fetched a playful cuff to the boy’s head, sending him running down the stairs. Crossing over to the pallet, Kulgan lowered his heavy frame to it and looked at the priest. “Boys,” said Kulgan, shaking his head. “You hold a festival, give them a badge of craft, and suddenly they expect to be men. But they’re still boys, and no matter how hard they try, they still act like boys, not men.” He took out his pipe and began filling it. “Magicians are considered young and inexperienced at thirty, but in all other crafts thirty would mark a man a journeyman or a master, most likely readying his own son for the Choosing.” He put a taper to the coals still smoldering in Pug’s firepot and lit his pipe.

Tully nodded. “I understand, Kulgan. The priesthood is also an old man’s calling. At Pug’s age I still had thirteen year of being an acolyte before me.” The old priest leaned forward. “Kulgan, what of the boy’s problem?”

“The boy’s right, you know,” Kulgan stated flatly. “There is no explanation for why he cannot perform the skills I’ve tried to teach. The things he can do with scrolls and devices amaze me. The boy has such gifts for these things I would have wagered the makings of a magician of mighty arts. But this inability to use his inner powers...”

“Do you think you can find a solution?”

“I hope so. I would hate to have to release him from his apprenticeship. It would go harder on him than had I never chosen him.” His face showed his genuine concern. “There is something else inside that boy’s head, something I’ve never met before, something powerful. I don’t know what it is, Tully, but it rejects my exercises, as if they were if somehow... not correct, or ... ill suited to him. I don’t know if I can explain what I’ve encountered with Pug any better. There is no simple explanation for it.”

“Have you thought about what the boy said?” asked the priest, a look of thoughtful concern on his face.

“You mean about my having been mistaken?”

Tully nodded. Kulgan dismissed the question with a wave of his hand. “Tully, you know as much about the nature of magic as I do, perhaps more. Your god is not called God Who Brought Order for nothing. Your sect has unraveled much about what orders this universe. Do you for one moment doubt the boy has talent?”

“Talent, no. But his ability is the question for the moment.”

“Well put, as usual. Well then, have you any ideas? Perhaps I would be well advised to seek another master for Pug, place him with one better able to harness his abilities.”

Tully sighed. “I cannot advise you. Still, as they say, a poor master’s better than no master at all. How would the boy have fared if no one had chosen to teach him?”

Kulgan bolted upright from his seat “What did you say?”

“I said, how would the boy have fared if no one had chosen to teach him?”

Kulgan’s eyes seemed to unfocus as he stared into space. He began puffing furiously upon his pipe. After watching for a moment, Tully said, “What is it Kulgan?”

Kulgan said, “I’m not sure, Tully, but you may have given me an idea.”

(continued in “Magician” from Doubleday books)

FAN GUEST OF HONOR

Sue Potter

Many of you who attended the Phoenix WesterCon in 1982 may remember Susan Potter, our Fan Guest of Honor. She worked in our con suite, as she has at many west coast conventions in her guise as the MOTHER GODDESS. To refresh your memory she is a 5'4" amber red-head that bears a **strong** resemblance to your average fertility idol. She is one of the most competent*, capable*, efficient*, and effective* workers at a convention. Sue has worked BayCons, WesterCons, Loscons, Contacts and other west coast cons. If all this isn't enough her level-headed* personality and sparkling* good looks makes any convention more enjoyable for all concerned, workers and attendees alike.

Sue was asked if she wanted to put anything about herself in the program book. The following is her reply.

They tell me that I may use this space to explain and/or defend myself. So.. First the defense;

I confess I am the one who started the comment "There IS a difference between eyetracks and fingerprints." and "Can I please have a smoking gopher?"

Now for the explanation;

For me, working at a con is as addictive as air. From the first sampling I haven't quite been able to stop myself.

I walked into a science fiction, horror, and fantasy con one Easter weekend and decided that the best way to find out what was going on

was to volunteer. Well, one thing led to another and I went from gopher at registration to Hostess in the Green Room that weekend.

I went home wanting more, but thinking that it could never happen again. (So naive!!) A few months later that ominous first letter came, (those of you who have worked at cons know it...the one that starts " I remembered working with you at") and off I went.

Being convention happy, a glutton for punishment or a sucker (depending on your



definitions) [Sue is all of the above and more. ed.] makes it easy for a Concom to snare you. I think “they” wander around at cons looking for the open mouths to put their hooks in. [Sue should know as she’s hooked her share. ed.] It also had me combining Green Room and Hospitality into one job to make the purchasing job easier..Such a fool. This, of course, led to helping with Security and Press—logical extensions of hospitality, I thought.

I don’t remember when I switched from staff to committee, it must have happened while I was icing sodas. Once I was in on the planning I couldn’t help but put my 2 cents in. So I started doing my own purchasing..Hmm, a method to the madness, eh? Maybe it was a misguided maternal instinct that kicked over but watching people go hungry because they couldn’t eat the food served offended my sense of fun. Grumbling tape worms do not work as a harmony to conversation. So menu changes for hospitality became my not-so-secret project.

Being (honest and truly, I swear) shy around strangers helped me out, for as long as I had something real to do I could handle talking to anyone. I keep working sometimes to keep from hiding.

My success at buying what I wanted when they let ME control the money,(i.e. do the shopping) and juggling it all seems to have set me up here as a mobile target. And it seems to have set me on a career (how many times has this happened in fandom?) I currently work as a Catering Coordinator for Fillmore Fingers, working with events, productions, private parties, and conventions. The only difficulties are in realizing that they actually PAY me \$\$money\$\$ to do this and explaining that I really CANNOT work any slower.

All in all being able to “share the joy” (work) at cons and seeing how caring for and about others can and does keep this universe stable has been something I wouldn’t have missed. Thanx for sharing all your realities of wonder with me, be seein” ya!

Sue

*** Note, Sue said she’d kill us if we used the words pert, perky, cute, bouncy, cuddly, vivacious, or bubbly. After meeting her you might find it appropriate to substitute any of these words for the noted words. We, of course, have not used any of these words but you may if you like! (We love you, Sue. Terry and Deb)**

ART SHOW

Ray Gish

The Phoenix Ballroom is once again the home of the LepreCon art show. Hours are: Friday 12 noon - 8:45 P.M.(closed from 7-8)
Saturday 10:00 A.M. - 7:00 P.M.
Sunday 10:00 A.M. - 12 noon

The auction will be held in the Borein Room starting at 1 P.M.

Some of the best artists in the science fiction/fantasy genre will be showing in the LepreCon 13 art show. Alan Gutierrez, Alicia Austin, Armand Cabrera, Dexter Dickinson, and lots of other outstanding artists will be offering their work for sale and your enjoyment. Everyone should wander through the show to see the fruits of their labors, a feast for the eyes.

There will be a special art show tour conducted by one of our attending professional artists on Friday night from 9-10 P.M. Attendance will be limited to 25, sign up in advance in our Green Room (Board Room).

Artists may pick up their unsold pieces starting Sunday noon. Buyers should pick up their purchases after the auction. Pieces with two or more bids will go to auction and other pieces may go at the art show director's discretion.



PROGRAMMING

Marianne Sutton

Programming is located in the Borien, Russell, and Regency Ballroom. A pocket program with exact schedules (!?) is available at registration. Any(all) changes will be shown on the schedules posted outside the individual rooms.

Did you ever open the lid to the laundry hamper and ask "What's that cat doing in here?" That's the title of a panel discussing how animals can turn up in the oddest places — art, literature, and space.

Speaking of art, (and we will, a lot) there's some practical advice on marketing art, and how you can help yourself to move from an amateur to a professional status artist. And just for all us fans who like art but don't know an intaglio from a toenail, there's a panel on defining art terms — **I Don't Know Much About Art, But...**

Marketing also comes up regarding books (are you surprised?) and there's a look at trends in science fiction and fantasy (is there life after cyberpunk?).

On Saturday G. Harry Stine will be "awing the masses" with the (very real and right now) commercial possibilities of space, and Phil Foglio will be ready to "capture" our imagination and answer your questions on the existence of gremlins. That's the day to learn as well about practical costuming, art techniques and round-robin adventure gaming.

Child of What If? repeats last year's look at serious answers to silly questions, and vice versa. (Whatever happened to the guy who said, "What's good for General Motors is good for America" — and what did he really say?).

Want to run play-by-mail games, hear what it takes to build the "perfect con" (three walnut shells and a pea, last I heard), or come up with some good artistic reasons why you should buy that \$1.75 *Fully Automatic, Radioactive Tamper-Proof Seals* comic book? It's all here, and much more.

Several of the events require preregistration (indicated by a * in the pocket program); these include the guided tour of the art show, the art techniques workshop, the Trivial Pursuit™ (board game) competition, and the pun contest.

Arizona Book Cache

4605 W. Indian School, Phoenix
(602) 278-1130

**New and Used Books
Sold and Traded
Custom Painted Dragons
10% Discount on Comics
Full Line Of Minatures and Paints**



Don't Forget Cache-Con 87
October 30, 1987 6 P.M.

Featuring :

**Alan Dean Foster
Jennifer Roberson
G. Harry Stine
Paul Cook
Michael McCollum
Alan Gutierrez
Rick Cook
Paul Edwards
Plus More to Come**



**Fun, Music, Prizes,
and Surprises**



Basket Cases
278-1130 - Ellen McCrea
Baskets For All Occasions and Moods

Space and time has been set aside Friday evening for panels and meetings by organized groups. (Unorganized groups will have to find their own space and time — and napkins. I can't do everything for you.) Take this opportunity to learn more about some of the local fan groups.

There's a dance planned after the Masquerade Saturday night. And be sure to attend our "Meet the Pros" at 7 p.m. Friday in the Atrium. My theory is conventions are nature's way of telling you to meet new friends, and this is a good opportunity.



ARIZONA'S #1 SOURCE

FOR FANTASY • COMICS • SCIENCE FICTION



- OVER 100,000 COMICS FOR COLLECTORS
- ALL THE NEW MARVEL, DC, AND INDEPENDENTS
- COMIC BOOK RESERVATION SERVICE
- COMIC BAGS, BOXES, AND INDEXES
- ARIZONA'S MOST COMPLETE SELECTION OF NEW AND USED SCIENCE FICTION/ FANTASY BOOKS AND MAGAZINES
- GAMES, PORTFOLIOS, POSTERS
- COMPLETE LINE OF DR. WHO MERCHANDISE

THE ONE BOOK SHOP

710 S. FOREST AVE., TEMPE, AZ 85281

(602) 967-3551

JUST 1/2 BLOCK NORTH OF THE ASU CAMPUS

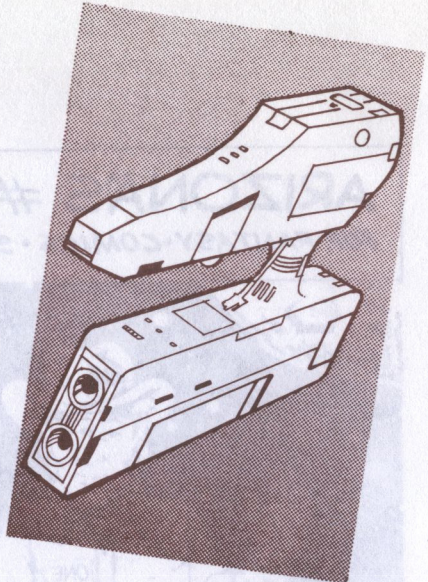
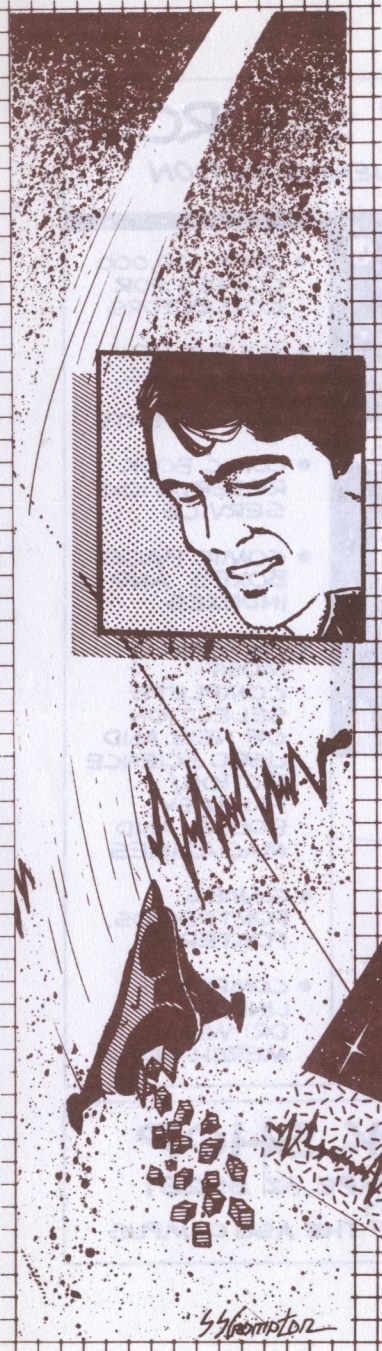

Steve Crompton

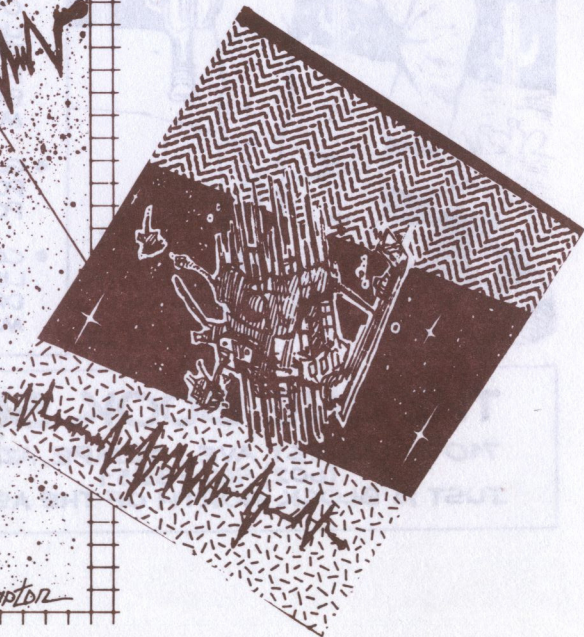

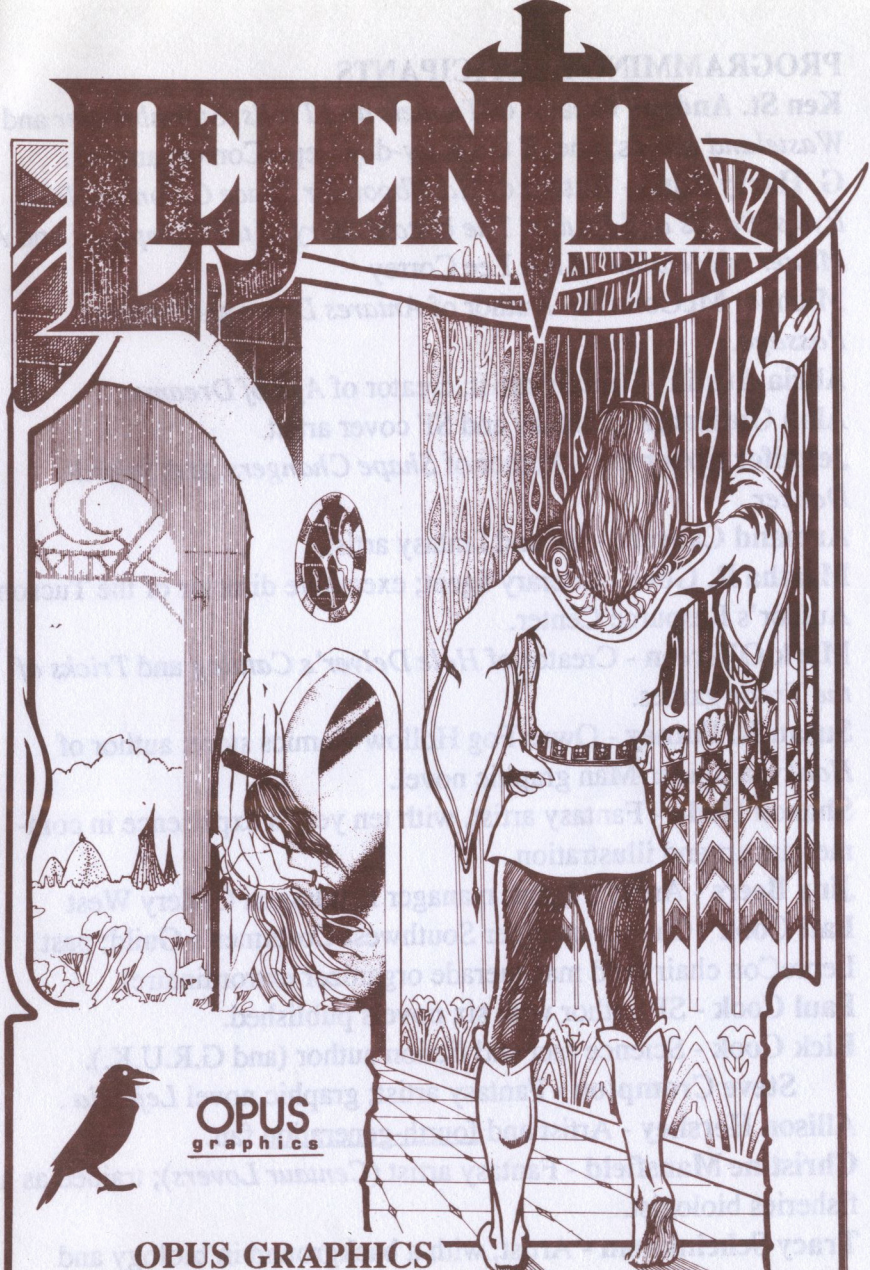

OPUS
graphics

**OPUS GRAPHICS
IS PROUD TO PRESENT**

The First 500 signed and numbered copies of
Lejentia -- the Graphic Series at Leprecon 13
(Look for our booth in the dealer's room)

Also: Lejentia Campaign Adventures will be
running Saturday in the gaming room

PROGRAMMING PARTICIPANTS

- Ken St. Andre** - Creator of *Tunnels and Trolls*, *Stormbringer* and *Wasteland* games; one of the early-day LepreCon organizers.
- G. Harry Stine** - Author of *Handbook for Space Colonists*; *Bits, Bytes, Bauds and Brains: The Untold Story of the Computer*; and *A Matter of Metalaw*. AKA Lee Correy
- Michael McCollum** - Author of *Antares Dawn* and *Antares Passage*.
- Alicia Austin** - Fantasy artist; creator of *Age of Dreams*.
- Alan Gutierrez** - Fantasy and SF cover artist.
- Jennifer Roberson** - Author of *Shape Changers*; and *Sword-Dancer*.
- Armand Cabrera** - SF and fantasy artist.
- Martha R. Gore** - Literary agent; executive director of the Tucson Author's Resource Center.
- Mark O'Green** - Creator of *Hole Delver's Catalog* and *Tricks of the Trade* games.
- Susan K. Putney** - Owns Fog Hollow Comics store; author of *Hooky*, a Spider-Man graphic novel.
- Sharon Hodd** - Fantasy artist, with ten year's experience in commercial art and illustration.
- Jinx Beers** - Artist's agent, manager Pendragon Gallery West
- Pati Cook** - Charter member Southwest Costumer's Guild; past LepreCon chair (and masquerade organizer extraordinaire).
- Paul Cook** - SF author with six novels published.
- Rick Cook** - Science fact and fiction author (and G.R.U.K.).
- Steve Crompton** - Fantasy artist; graphic novel *Lejentia* .
- Allison Hershey** - Artist and fourth-generation fan.
- Christine Mansfield** - Fantasy artist (*Centaur Lovers*); trained as a fisheries biologist.
- Tracy Scheinkman** - Artist, with a background in biology and wildlife behavior.
- Rikki Winters** - Artist; active in Phoenix fandom.
- Mel White** - Artist with contributions to more than 200 fanzines; currently collaborating with Robert Aspirin on *Duncan O'Mallory* graphic novels.

The party's on!

with

**HARLAN
ELLISON**

and

**ROBERT
SILVERBERG**

at the

18th annual



Other guests:

WILL EISNER
BERNI WRIGHTSON
ART SPIEGELMAN
FRANCOISE MOULY
SERGIO ARAGONES
B KLIBAN
BILL MUMY
MIGUEL FERRER

Featuring:

- *Science fiction panels and readings
- *Largest costume competition held annually in Southern Calif.
- *Spectacular parties and dances
- *Well-stocked con suite
- *Gaming rooms and programs
- *Art show and auction
- *Extensive film schedule
- *Japanese animation
- *And much, much more

August 6-9, 1987

- *Holiday Inn at the Embarcadero
- *San Diego Convention and Performing Arts Center
- *\$25 4-day memberships, until April 30
- *\$30, May 1-June 30
- *\$35, at the door
- *Kids 7-16 half-price
- *Under 7 free with adult member

For more information:
San Diego Comic-Con
P.O. Box 17066
San Diego, CA 92117
(619) 442-8272

OH BOY! ITS

TUCSON TV AT THE EXECUTIVE INN, TUCSON

OCT. 2-4

TIM POWERS, GOIT
ED BRYANT, TOASTMASTER
JIMMY SUCHART, FGOIT!

ARTSHOW, DEALERS, CONSULTE
MASQUED. BALL, MOVIES,
PROGRAMS AND PARTIES!

CHEAP ROOMS - \$30 SGL
\$34 DBL.

LEPRECON SPECIAL!
\$12 MEMBERSHIPS
(otherwise \$15 4:1 9/1
\$20 AT THE DOOR)
DON'T MISS IT!



ANOTHER WEIRD AD BY DEON

FOR MORE INFO: PO BOX 26822 TUCSON AZ 85726

DEALERS ROOM

Dave Hiatt

The Dealers Room is located downstairs in the Regency Ballroom this year. The room hours are: Friday 12:00 Noon to 7:00 PM
Saturday 10:00 AM to 6:00 PM
Sunday 10:00 AM to 4:00 PM

A few of the dealers that we have in attendance this year include:

The Rakish Blade

Roaming Panther Gaming

Roderick the Sly

Jim Grant

Fog Hollow

Paul Lindberg

Bryan Barrett Books

AZ. Holt Assoc.

PFFS

Comic Locker

Barry Bard

Mere Dragons

Nighthawk Studios

Peggy Zimmerman

Endless Universe

DAG Productions

Motley Merchandise

AZ. Book Cache

M.R. Hildebrand/L. Fish

Marty Massoglia

James Reade

Patrick Connors

There will be no smoking in the dealers' room, because of the new city ordinances. The hotel has a policy which restricts the consumption of food or drink not purchased from the hotel in all function space. The convention asks that these rules are honored by everyone, members and dealers alike. Smoking will be allowed in the foyer of the ballroom.

Come on down to see all the goodies our dealers have to offer. Buy something new, or something old. But you will have to find something borrowed and blue by yourself.



GAMING

Chip Pitcher

We have some outstanding events planned in the gaming area this year at LepreCon. There will be two Sanctioned TSR tournaments, AD&D and Marvel Superheros. Members of the RPGA even get club points. We will also be running a Sanctioned D.C. Hero and another game from Mayfair. Fantasy Games Unlimited is loaning us Scott Bizar, and he will be running several of their board games and he is also bringing in LOTS of door prizes made up of assorted goodies. A HUGE Modern Micro-Armor game/ tournament is also planned, so bring your Modern M/A.

Some other things we have planned are Star Fleet Battles (run by Ol' Dave), open gaming, panels by Ken St. Andre and others, limited game check-out, and other goodies. We will have door prizes donated by Fantasy Games Unlimited, a raffle for participants of tournaments and an auction with lots of goodies near the end of the convention.

We still need some interested (or perhaps interesting) people who are willing to run some individual games. If you have any questions or any ideas, come up to the Gaming room in the Cowboy Artists Room. Maybe you too can conquer a new universe or ride a dragon during a Fall. Enjoy!!



LEPRECON COSTUME EVENT

Pati Cook

The Costume Event (aka Masquerade) will be held Saturday evening at 8:00 P.M. Registration will take place at the contestants' meeting Saturday afternoon, please see the pocket program for time and place. All forms, tapes, etc will be turned in at this time. ALL entrants must be present. Entrants will report to the assigned area by 7:00 P.M. on Saturday evening. (Note; If you are unable to attend the contestants' meeting, arrangements need to be made in advance.)

An entry fee of \$1.00 pays for a Polaroid print used by the judges and given to the contestant after the competition, the fee may be waived if the entrant provides a recent photo of himself in the costume. Extra Polaroids may be available at \$1.00 each.

We will run the event under a division system:

Young Fan — under the age of 12.

Novice — anyone who has entered 3 or fewer costume events.

Apprentice — anyone who has entered several events, but does not qualify as a Journeyman.

Journeyman — anyone who has won in a costume event.

Artisan — anyone who has won 3 or more awards at a major regional convention (not including WorldCon).

Master — a costumer who has won 3 or more awards at a WorldCon, or once as a Master anywhere.

We will also have three categories of costumes:

1. Original science fiction / fantasy.
2. Re-creation science fiction / fantasy.
3. Historical costumes.

Hall Costumes are ineligible for competition in the event — they will be judged in the halls. There will be a chance for hall costumes to parade across the stage while the judges are doing their deciding.

Everybody is more than welcome to come and participate in the event. If you have something that you have been wanting to say (as in the Keebler Elf Questers at last CopperCon) or you just want to be seen, come on out and strut your stuff. See you all there.

LEGENDARY

★ ★ ★ ★

-Different Worlds

"A game which an experienced player can enjoy, but a player can also bring in a novice and teach him or her the basics of role playing . . ."

-Comics Collector

"DC Comics is represented in the superhero role playing game field with a powerful new entry . . . the best that Mayfair has done yet."

-Dragon Magazine

WINNER of the 1986
Charles Roberts
Award for Best Role
Playing Rules.

Mayfair Games' *DC Heroes Role-Playing Game* is available at fine comic & hobby shops everywhere. Don't miss it!

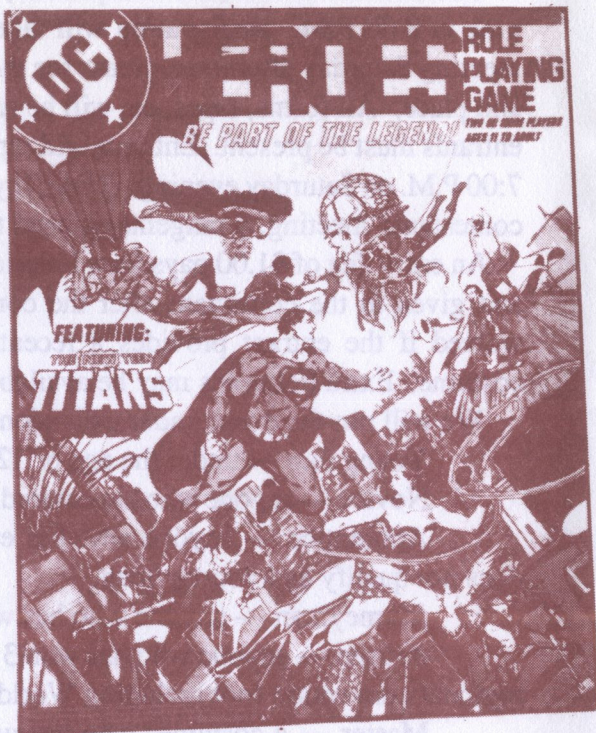

Mayfair Games Inc.

™ Indicate Trademark of DC Comics Inc. All character names, renditions, associated slogans, and indicia are Trademarks of DC Comics Inc. Copyright © 1987 DC Comics Inc. All Rights Reserved.



Bill Rotsler



JAPANIMATION

Tom Perry

What's the big deal about Japanimation and why are we showing so much of it at LepreCon? The simple reason is that we enjoy it and hope that you will too. After all, that's what we're here for. If that answer is too simple for you, then read on.

The big deal is that Japanimation is cartoons for all ages. As children, we enjoyed animated cartoons at movie theaters and on television. Unfortunately, as we grew older, American animation seemed to grow less mature until it is now aimed at an audience of 4-10 year olds.

This was not true in Japan where the major studios refused to limit their market to little kids, but began making serious works for older audiences. The difference is so profound that many American fans prefer to use the Japanese word "anime" to describe the Japanese animation.

Many of their movies have excellent characterization with real people who do things for intelligent reasons. The storytelling is frequently superb, having complex plot lines leading to unexpected endings. It is not uncommon to have the hero (and everyone else) die during the course of the movie.

The artistic style is distinctive and readily recognized. It is characterized by uncommonly large eyes, brightly colored hair (green and blue hair is common), and the use of bright, highly saturated colors. Not only are the characters bigger than life, they are often brighter than life as well.

And finally there is the sheer diversity of Japanimation. Any topic is suitable, including horror, science fiction, baseball, soccer, detective drama, sword and sorcery, motorcycle racing, pornography, fantasy, mythology, samurai/ninja adventures, comedy, religion, mutants/psionics, boxing, romance, etc. There is material to please anyone.

Now, why do we show so much of it at LepreCon — a convention oriented towards science fiction/fantasy and art? A lot of Japanimation is based on science fiction/fantasy themes (and it's not all giant robots, either). "Lensman" is based on E. E. "Doc" Smith's "Lens-

man" series. "Time Stranger" is a serious look at time travel and an attempt to change the past. "The Humanoid" deals with a robot who falls in love with a man. Japanimation is one of the few places where one can find serious science fiction in animated form. In addition, the artistic styles present in Japanimation are influencing an increasing number of American and European artists. As you go through the art show, you are likely to find a number of artists whose works show Japanimation art influences.

But the first answer is still the best: we show it because we like it. ENJOY!

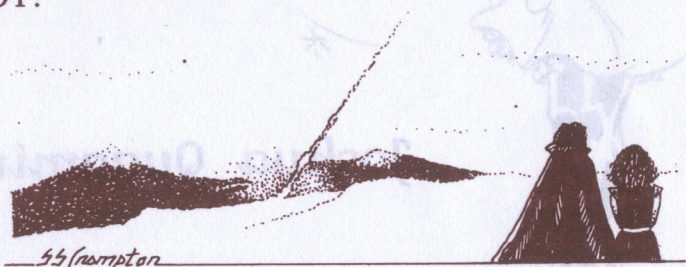

A SHORT LESSON IN HISTORY

by John and Kandy "I knew I should have gone to the meeting" Fong

Very, very late at the end of a Con, when the bheer is reduced to the last few cans in the ice filled tubs, the tribe of fans, fen and phans gather together. In the bardic traditions of Olde, the favorite stories from the early days of LepreCons are retold and grow in the retelling.

The tales start in 1975 with the first LepreCon. Three times Gregg Brown led a hardy band of local wanderers - west, east, and north - in search of the perfect Con. With number four, the mantle of Head Scapegoat fell to Hilde Hildebrand, then to a different fan for each con. For, in the oldest fannish tradition - each attendee knows exactly the best way to run a con and how to return to the glory of bye-gone days of supermembership dinners and book races (using your nose) across the hotel lobby.

Yea, the tales of Barry's green bagels (and their colorful results), the spaghetti that wouldn't cook and many more will live long in the oral histories of Phoenix Fandom. So, dig through the ice to find your favorite drink, then curl up on the couch or floor in the Con suite and listen to the fans talk.



Joshua Quagmire

Joshua
Quagmire
2005



Joshua
Quagmire
2005

FOG HOLLOW COMICS

New and Old Comic Books
Fantasy Role-Playing Games
Posters, Buttons, T-Shirts, Books, & More

We will not be oversold!
If you find a higher price elsewhere,
tell us and we will beat it!

Our video games are the oldest!
Our dog is the slowest!
Our bathroom teleports!

Fog Hollow Comics
3215 E. Thunderbird Rd.
Suite #203
Phoenix, Arizona 85032

Open:
Sunday: noon-6
Monday -Thursday: 11-7
Friday and Saturday: 11-8.

The Friendliest Comic
Shophe in the West!

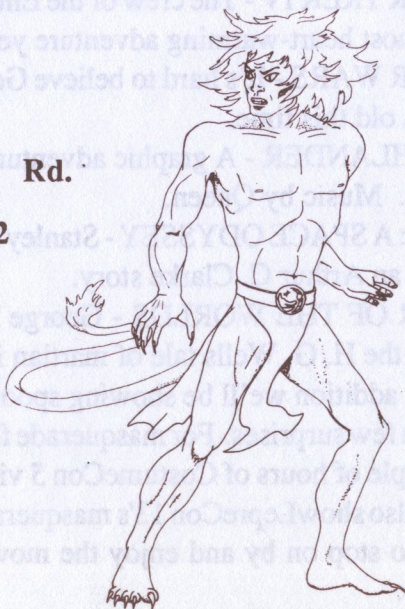

LEPRECON 13 MOVIE PROGRAM

David Storck

The film program this year will again be shown on a 6 ft. video screen in the Curtis Room. Check the pocket program and the marquee outside the door for the exact list of films and times.

Films will begin at 10:00 AM Friday and will run well into Sunday afternoon. Midnight showings are scheduled for Friday and Saturday nights. Many films will be shown twice for your convenience.

A list of a few of our confirmed films:

ALIENS - Ripley is back, with her Marine commandos, to do battle with those icky aliens.

DR. STRANGELOVE or: HOW I LEARNED TO STOP WORRYING AND LOVE THE BOMB - Peter Sellers has three roles in Stanley Kubrick's black comedy of nuclear politics.

JASON AND THE ARGONAUTS - One Ray Harryhausen's best in this mythical tale of Jason's search for the Golden Fleece.

THE ROAD WARRIOR - Mad Max is back again in this visually stunning action-adventure.

STAR TREK IV - The crew of the Enterprise comes home. Probably the most heart-warming adventure yet.

STAR WARS - It's hard to believe George Lucas' blockbuster is ten years old this time.

HIGHLANDER - A graphic adventure showing the price of immortality. Music by Queen.

2001: A SPACE ODYSSEY - Stanley Kubrick's milestone space epic from an Arthur C. Clarke story.

WAR OF THE WORLDS - George Pal produced this 50's classic from the H. G. Wells tale of martian invasion.

In addition we'll be showing spoofs, bloopers, cartoons, trailers, plus a few surprises. For masquerade fans, John Fong will be showing a couple of hours of CostumeCon 5 video on mid-day Saturday. We will also show LepreCon 13's masquerade video late Sunday morning.

So stop on by and enjoy the movies and don't forget to phone home.



Armand Cabrera

AC 85

CONVENTION OFFICE

Eileen Phillips

The Convention office is located in Remington C, next to the Art Show. We are open 24 hours a day waiting to assist you in any problems that you may find during the convention. If you have lost something and want to find it or you have found something and want to lose it, come by and see us. We will also be the home of after-hours registration, so if you have your friends coming in late, this is the place to be.

We're also looking for a few good fen. If you've ever wanted to see how a convention runs from behind the scenes and are planning on attending CactucCon (NASFiC) in September, stop by the Convention office and talk to Eileen Phillips. Volunteers will be gratefully accepted and very seldom will be sacrificed.

VOLUNTEERS

Ken Lemons

Conventions don't run themselves! They are run by fans, just like you, who love conventions and are willing to help everyone have a good time by helping out with the chores. If you are one of those special people who enjoy being IN on the organization, or if you just want a change of pace, or if you have a couple of hours for the frivolity of chopping veggies, come by the convention office in Remington C and see Ken Lemons. He will do his best to find you a job to fit your talents and tastes. If everyone works 1 hour at a convention everything will get done and we can all get down to serious FUN. If you are wandering the halls with nothing particular to do, look around for a help wanted sign. This means that area of the convention need volunteers for a short period of time, stop in and lend a hand. We thank you all in advance for helping the committee in making this a terrific LepreCon.



Karen

Karen Kuykendall

Los Angeles in 1989 Westercon 42



You haven't partied this hard since
the
Mesozoic!

Write to us, C/O S.C.I.F.I., Box 8442, Van Nuys, CA 91409

Karen Kuykendall

SECURITY

Jim Webbert / Pat Norris

I am the Chief, thy Security. Thou shalt have no other blankets before me.

Thou shalt not wear real or realistic firearms, nor weapons that shoot or project anything.

Thou shalt not wear spiked apparel.

Thou shalt have a "hard protective" case that will protect anybody from the point or edge of thy knife or thy sword. Exceptions to the above may only be granted by the joint approval of Pati Cook and Pat Norris or Jim Webbert and only for the duration of the Masquerade.

Thou shalt not sleep in areas that are not set up for sleeping and not in convention function space.

Thou shalt not profane the language of common sense, nor shalt yea interfere with the doings of your neighbors or your neighbor's wife. Thou shalt instead remember that all around you have their rights and you may not impose upon them as they may not impose upon yours.

Thou shalt not drink alcohol if thou are underage. If thou weren't born before Jan. 1, 1966 thou art too young to imbibe.

Thou shalt remember that all hallways are actually walk-ways and thou shalt not run.

Thou shalt remember that badges pulled for cause, as stated by the head of security, will not be refunded. The convention shalt retain the right to remove any individual who cannot work within the confines of common courtesy and common sense.



Thou shalt remember the convention and keep it fun, for it was conceived that a weekend shall be set aside every year for this convention and we shalt do our best to insure that we can have one every year.

Thou shalt enjoy this weekend and partake in all the delights of this land. This weekend was set aside for the enjoyment of all and to all a good night.

ADAM'S BOOKSTORE
15214-A N. Cave Creek Road

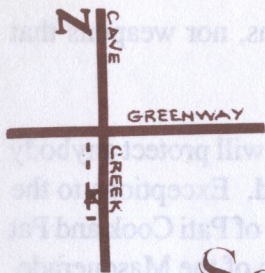

**Used & Rare
Fantasy &
Science Fiction**

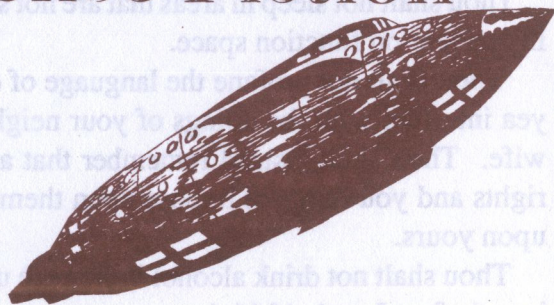

**Robert A. Heinlein
Frank R. Stockton
Piers Anthony
Philip Jose**

THE NEW FORCE IN

Phoenix

602-493-0505

OPEN 7 DAYS

CON SUITE

Julie Douglas and House Blackwater

The Hospitality Suite for LepreCon 13 is planned as a place for civilized conversation and quiet relaxation. The suite will be open for business from noon till the end of the universe. The only exception to these hours are that the Con Suite will be closed from 7:00 PM to 8:00 PM on Friday for the Meet the Pros Party and on Saturday night during the Masquerade. The suite will occasionally close during the day for short periods of time for general clean-up and the restocking of the stale popcorn so that the room will be ready for you to frolic.

Delicious discourse and quiet disagreements are encouraged, to be abetted by non-alcoholic beverages to keep the whistle wetted and plain but abundant munchies to soothe the inner person.



Paper and pencil will be provided for devious diagrams and scurrilous verse, as well as exchanged addresses and dippy doodling.

As the Con Suite will be located just off the swimming pool, bathing suits are permitted with the addition of a blotter beneath to keep the furniture dry. With the swimming pool nearby, please remember that the only type of containers allowed on the pool deck are of the plastic, non-breakable, variety.

Rowdiness and obnoxious drunks will be firmly discouraged. Party drunkenness shall be held elsewhere. Persistent cases of any of the above will be gently deposited somewhere in the Salt River.

So — if your feet hurt, if your parched tongue and cracked lips need liquid applied, if you are looking for a place to hold a sitting down conversation with that fascinating person you met in the hall, join us in the Con Suite on the third floor pool deck and enjoy the most fascinating collection of people at the whole con. None other than the infamous Blackwater Con Sweeties (both male and female) who welcome you into our parlor.

REGISTRATION

Molly & Greg Hildebrand

Registration hours for LepreCon will be 9:30 AM to 9:00 PM on Friday, June 5th, from 9:00 AM to 7:00 PM on Saturday the 6th and 8:00 AM to 12:00 Noon on Sunday, June 7th. We do reserve the right to check ID when buying your membership so please have it available. If your badge is lost and you want a new one it will be full price. If you want to change the name on your badge, you will need to turn in your old badge and pay \$1.00. If any problems arise after registration has closed down, help will be available in Convention Operations. Hope you have an enjoyable convention.

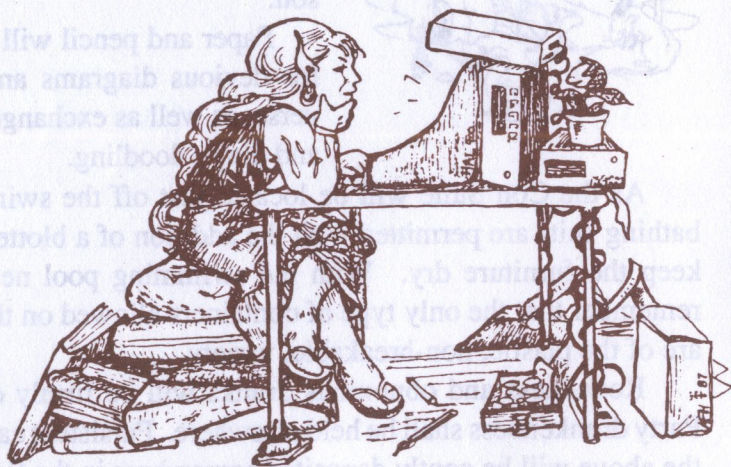

Computer Gaming

Bill Kendall

This year's computer gaming room will feature Duel Masters who will be running several games. In addition there will be lots of other games for your enjoyment.

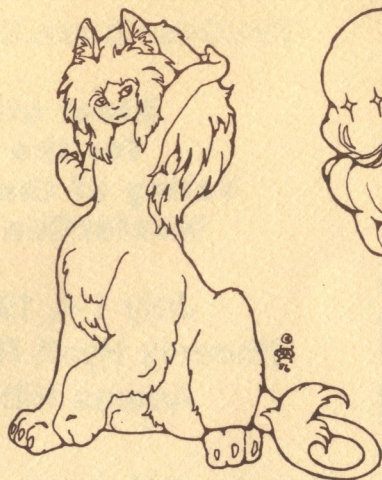
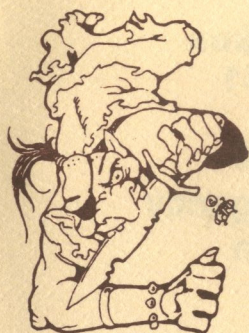

Mary Hanson-Roberts

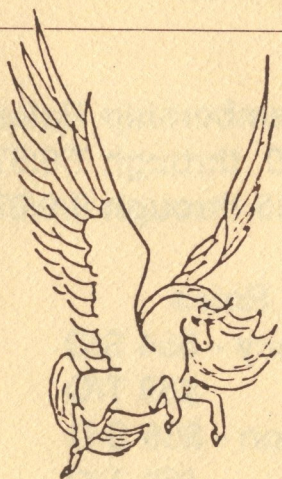

Pegasus
Creations

Calligraphy, Fantasy Art, Stationery,
Portraits in Pastel

To receive a catalog, send \$1 to:

Pegasus Creations
37 Carson Court
Ely Nevada 89301

And mention this publication!

The Countdown Continues

**Blast off
for the
Valley of the Sun
WesterCon 41**

**July 1-4, 1988
Phoenix Hyatt Regency
Adams Hilton**

**Guests of Honor:
Robert Silverberg
Craig Miller**

**Membership Rates
\$30 through 7/6/87
\$35 through 9/9/87**

**Hotel Rates
HyattRegency - \$54 S/D
\$59 T/Q
Adams Hilton - \$56 S/D
\$61 T/Q**

**Suites Available Through the
Convention Committee**

**For Further Information and
Memberships, write us at:
P.O.Box 26665
Tempe, AZ 85282**



Valley of the Sun WesterCon supported by C.A.S.F.S and
LepreCon, Inc